



Opalia™ Whirlpool Bath

- BN05 Opalia™ Whirlpool Bath Left Hand
- BN15 Opalia™ Whirlpool Bath Left Front Pump
- DA39 Opalia™ Whirlpool Bath Left Back Pump
- BN00 Opalia™ Whirlpool Bath Right Hand
- BN10 Opalia™ Whirlpool Bath Right Front Pump

Opalia™ Bath

9635 Opalia™ Bath

- Center Drain Location
- Accessories / Hardware:
 - Trip-Lever Drain Kit #X559
 - Rotary Drain Kit, 26" Cable #8730
 - TheraPro Jet Trim Kit: #D095
 - AccuPro Jet Trim Kit: #P555
- Trim Kit Finishes Available:
 - (827) – Chrome
 - (826) – Brushed Nickel
 - (849) – Oil Rubbed Bronze

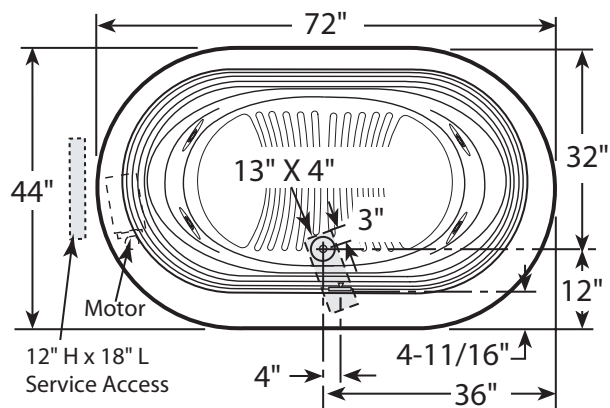

Product Shown: Opalia™ Whirlpool Bath Left Hand Shown
 Model: BN05

* Measurements inside unit represent cutout in floor to allow for drain/overflow.

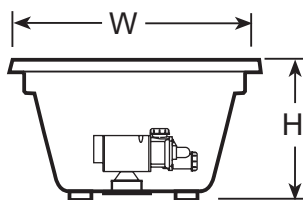

END VIEW

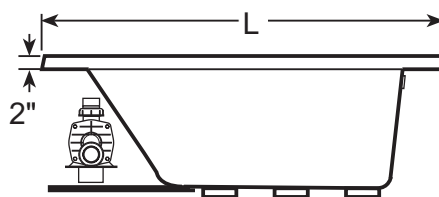

SIDE VIEW

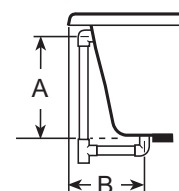

DRAIN/OVERFLOW

INSTALLATION NOTES

Refer to installation instructions included with fixture before beginning installation. Please confirm product availability and specifications before commencing with any installation work.

PRODUCT SPECIFICATIONS AND AVAILABILITY ARE SUBJECT TO CHANGE WITHOUT NOTICE.

Technical Specifications

DIMENSIONS

72" L x 44" W x 22-1/4" H
 (1829 mm) L x (1118 mm) W x (565 mm) H

DRAIN/OVERFLOW

A: 18-3/4" (476 mm) B: 12" (305 mm)

CUTOUT

Template Provided P/N GN52000

TOTAL WEIGHT

BN00: 978 lb (445 kg) / 45 lb/sq. ft. (217 kg/m²)
 BN05: 945 lb (429 kg) / 45 lb/sq. ft. (217 kg/m²)
 9635: 945 lb (429 kg) / 43 lb/sq. ft. (210 kg/m²)

OPERATING GALLONAGE

70 U.S. Gal. (265 Liters)

PRODUCT WEIGHT

BN00, BN05: 145 lb (66 kg)
 9635: 112 lb (51 kg)

SKIRT MOUNTING

Not Available

ELECTRICAL SPECIFICATIONS MODELS BN00, BN05 ONLY

Requires a dedicated GFCI protected separate circuit.

Motor/Pump: 120 VAC, 15 AMP, 60 Hz.
 RapidHeat™: 120 VAC, 15 AMP, 60 Hz.

HEATER (OPTIONAL) MODELS BN00, BN05 ONLY

Requires a dedicated GFCI protected separate circuit.
 RapidHeat™: P/N S750000